

REV.	NOTES	DATE
A	RELEASED	2023/01/04
B	依客户要求调整图面增加尺寸	2023/02/07

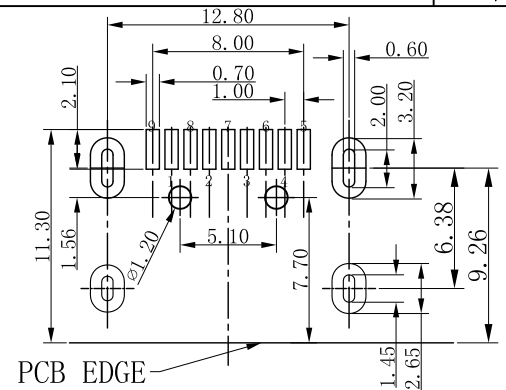
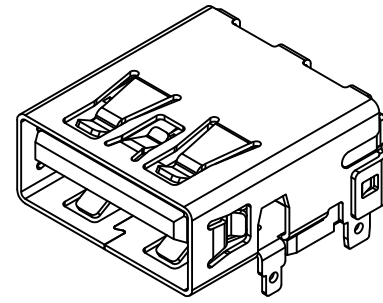
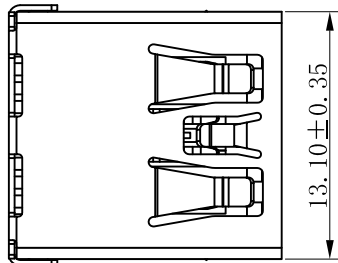

RECOMMENDED PCB LAYOUT

TOLERANCE: ± 0.05mm

NOTE:

- MATERIAL:
 - INSULATOR: HIGH TEMPERATURE PLASTIC UL 94 V-0; BLUE
 - CONTACT: BRONZE
 - SHELL: BRASS
- ELECTRICAL CHARACTERISTICS:
 - CONTACT RESISTANCE: 30mΩ MAXIMUM
 - CONTACT CURRENT RATING: 1.5A
 - DIELECTRIC WITHSTANDING VOLTAGE: 100 V AC R. M. S.
 - INSULATION RESISTANCE 100 MEGOHMS MIN
 - OPERATING TEMPERATURE: -40° C ~ 85° C
- MECHANICAL CHARACTERISTICS:
 - MATING FORCE: 3.57kgf MAX
 - UNMATED FORCE: 0.82kgf MIN AFTER TEST
 - DURABILITY MANDATORY: 1500 CYCLES
- PLATING
 - TERMINAL:
 - 30u" MIN NICKEL ALL OVER
 - 50u" MIN Tin ON SOLDER AREA
 - 0.6u" Au ON CONTACT AREA
 - SHELL: 30u" MIN. NICEL ALL OVER

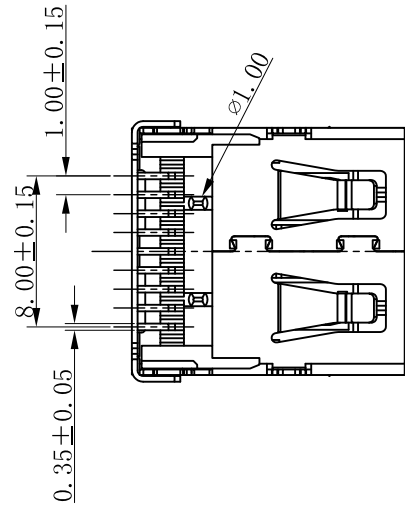
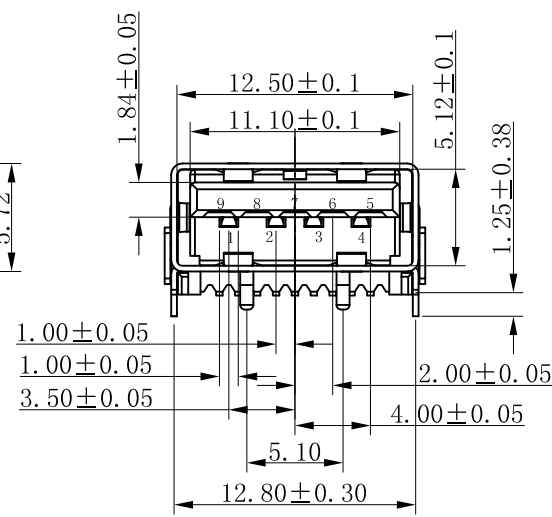
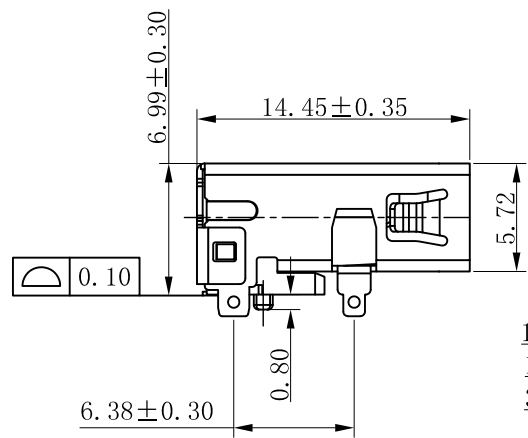

DIMENSIONS TOLERANCE METRIC	
X	: ±0.5
X.X	: ±0.30
X.XX	: ±0.20
ANGLES	
X	: ±1°
X.X	: ±0.5°

單位(UNITS)	mm	東莞翊豐精密五金有限公司			
數量(QT'Y)	N/A				
材料(MT'L)	SEE NOTE				
處理(FINISH)	SEE NOTE				
繪圖(DRAW)		圖名(NAME) USB 3.0 AF短体SMT无卷边(L=14.45)外壳四脚插板 带后盖塑胶长脚 ROHS			
設計(DE'N)		料號(PART NUMBER)	AAUS+A11F1-3307		
審校(CH'K)		圖號(DRAW NUMBER)			
核准(APP'D)		圖檔(FILE NAME .DWG)			
比例(SCALE)	1/1	圖紙(SIZE)	A4	頁次(SHEET)	1
		版次(REV.)	B		