

REV.	NOTES	DATE
A	RELEASED	2023/04/26

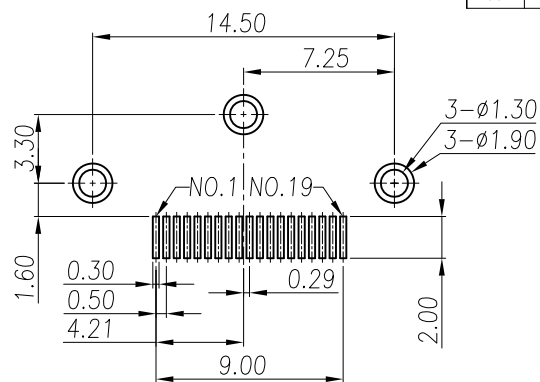
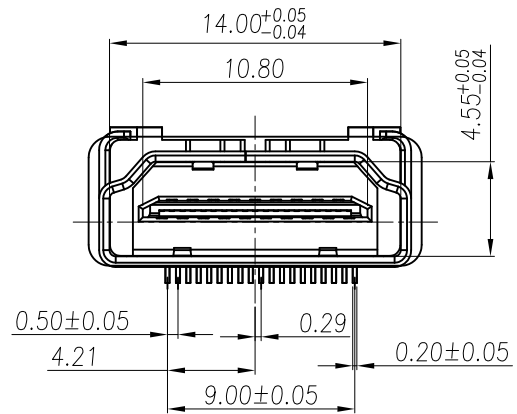

RECOMMENED P.C.B. LAYOUT(T=1.6mm)  
TOLERANCES UNLESS OTHERWISE SPEC.±0.05

NOTES:

- MATERIAL:
  - HOUSING AND COVER:LCP,UL 94V-0,COLOR:BLACK; HF
  - CONTACT:BRASS T=0.20;
  - SHELL:BRASS T=0.50;
  - CAP: LCP BLACK UL 94-V0
- FINISH:
  - CONTACT: Au PLATING ON CONTACT AREA,(SEE P/N DESCRIBING) AU G/F PLATING ON SOLDERTAILS,50u" MIN. Ni UNDERPLATING OVERALL;
  - SHELL: PLATING Ni 50u" MIN.
- SPECIFICATIONS:
  - VOLTAGE RATING: 40V
  - CURRENT RATING: 0.5A
  - INSULATION RESISTANCE: 100MEG.OHM MIN
  - CONTACT RESISTANCE: 30 MILL.OHM MAX
  - OPERATION TEMPERATURE: -20° TO +85°
  - INSERT FORCE: 44.1N MAX
  - EXTRACT FORCE: 9.8N MIN
  - DURABILITY: 5000 CYCLES

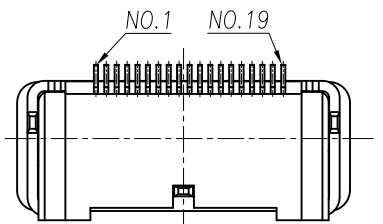
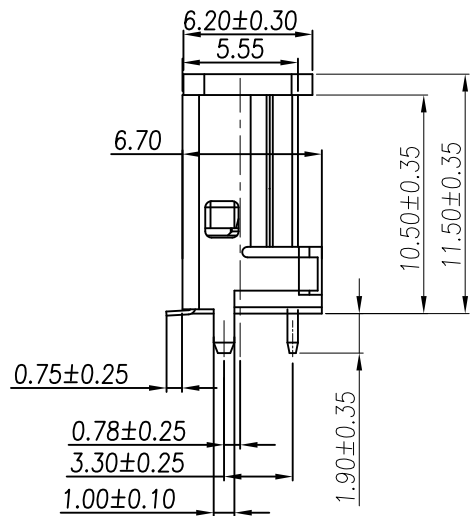
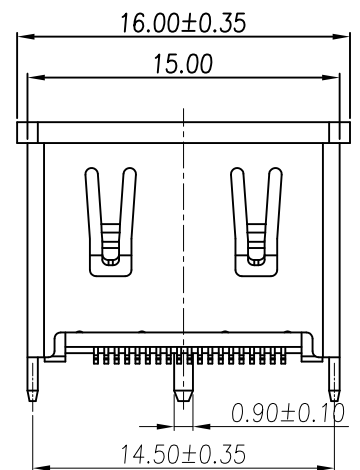

單位(UNITS)	mm
數量(QTY)	N/A
材料(MTL)	SEE NOTE
處理(FINISH)	SEE NOTE

東莞翊豐精密五金有限公司

繪圖(DRAW)	圖名(NAME)			
設計(DESIGN)	HDMI 19P/F 直立式SMT G/F LCP黑色銅殼 无LOGO ROHS			
審核(CHECK)	料號(PART NUMBER)	AAUS+19A53-0197R		
	圖號(DRAW NUMBER)			
核准(APPROVED)	圖檔(FILE NAME)	.DWG		
	比例(SCALE)	1:1	圖紙(SIZE)	A4
	頁次(SHEET)	1/2	版次(REV.)	A

DIMENSIONS TOLERANCE METRIC	
X	±0.38
XX	±0.30
XXX	±0.25
X.XXX	±0.15
ANGLES	
X	±1°
XX	±0.5°