

REV.	NOTES	DATE
01	RELEASED	2021/04/14

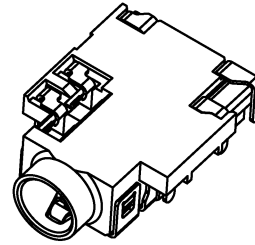

3D VIEW

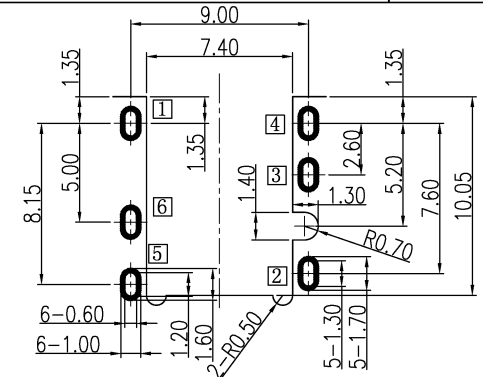

NOTES:

- MATERIAL: SEE "TABLE 1";
- FINISH: SEE "TABLE 1";
- ELECTRICAL:
  - VOLTAGE RATING: 12 VAC RMS;
  - CURRENT RATING: 1.0 AMP;
  - CONTACT RESISTANCE: 50mΩ Max.(Initial), 100mΩ Max.(After Life test);
  - INSULATION RESISTANCE: 100 MΩ Min., 500VDC.(Initial), 50 MΩ Min., 500VDC.(After Humidity test);
  - WITHSTAND VOLTAGE: 500 VAC RMS 50(60)Hz, 1 minute;
- MECHANICAL:
  - MATING FORCE: 0.5-2.2Kgf.(Initial); 0.4-2.2Kgf.(After Life test);
  - UNMATING FORCE: 0.5-2.0Kgf.(Initial); 0.4-2.0Kgf.(After Life test);
  - OPERATING LIFE: 5000 CYCLES MIN.;
- ENVIRONMENTAL:
  - SALT SPRAY: 48H.
  - OPERATION: -30°C~+80°C.

TABLE 1:

NO.	PART NAME	QTY	MATERIAL	DESCRIPTION	REMARK
⑧	Contact_5	5	1 Phosphor bronze	Au 0.6u"Min	T=0.20mm
⑦	Contact_6	6	1 Phosphor bronze	Au 0.6u"Min	T=0.20mm
⑥	Contact_4	4	1 Phosphor bronze	Au 0.6u"Min	T=0.20mm
⑤	Contact_3	3	1 Phosphor bronze	Au 0.6u"Min	T=0.20mm
④	Contact_2	2	1 Phosphor bronze	Au 0.6u"Min	T=0.20mm
③	Contact_1	1	1 Phosphor bronze	Au 0.6u"Min	T=0.20mm
②	Separator	1	HIGH TEMP. PLASTIC	Black	
①	Housing	1	HIGH TEMP. PLASTIC	Black	

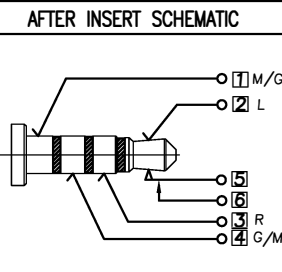
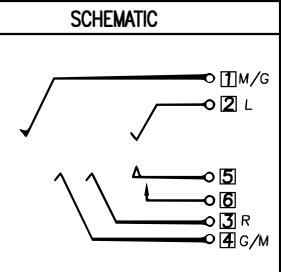
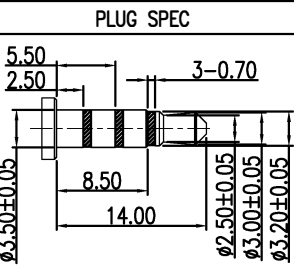
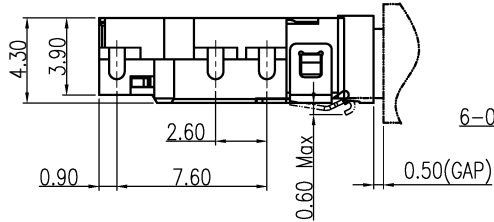
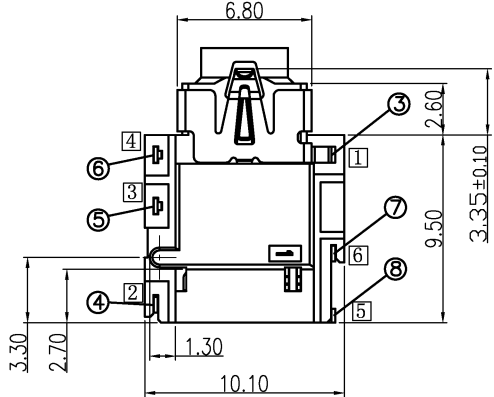
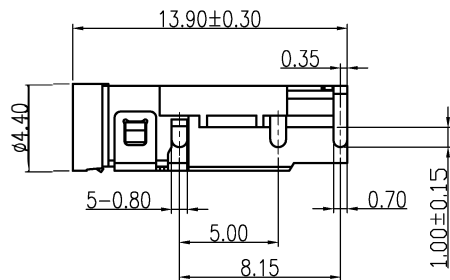
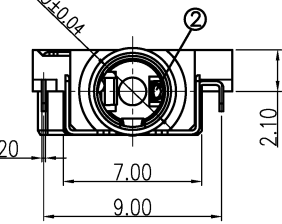
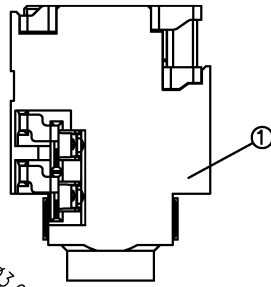

DIMENSIONS TOLERANCE METRIC

X :±0.5  
X.X :±0.38  
X.XX :±0.25

ANGLES :±1'  
X :±1'  
X.X :±0.5'

單位(UNITS)	mm
數量(QT'Y)	N/A
材料(MT'L)	SEE NOTE
處理(FINISH)	SEE NOTE
繪圖(DRAW)	
設計(DE'N)	
審校(CH'K)	
核准(APP'D)	

東莞翊豐精密五金有限公司			
圖名(NAME) ø3.5mm Phone Jack 沉板圓口			
料號(PART NUMBER)		AAPJ+3B06G1-02Z	
圖號(DRAW NUMBER)			
圖檔(FILE NAME .DWG)			
比例(SCALE)	1/1	圖紙(SIZE)	A4
頁次(SHEET)	1	版次(REV.)	01